

MACHINES POUR **SCIAGE, TRONÇONNAGE, USINAGE ET FRAISAGE**

ACIER / ALU / PVC

ASPIRATION POUR MACHINES INDUSTRIELLES

EISMO

LA
PUISSANCE
INDUSTRIELLE
au SERVICE
de VOS IDÉES

*depuis plus
de 47 ans*



EISMO

Anciennement EISELE DIFFUSION
10, rue de l'Artisanat - CS 70015
F - 68730 BLOTZHEIM

Tel. 03 89 68 45 66

Internet : www.eismo.fr

E-mail : eismo@eismo.fr

Octobre 1977 fut le départ d'une belle aventure industrielle pour notre société avec la **création de l'entreprise EISELE France**. Celle-ci fut implantée à Blotzheim (68) en Alsace, en face de l'EuroAirport de Mulhouse-Bâle. Pendant de nombreuses années, certaines tronçonneuses à fraise-scie acier ont été produites sur le site.



En **juin 1996**, EISELE France devient **EISMO (EISELE Machines Outils)**. Et en octobre 2024, **EISMO** fêtera déjà ses 47 ans ...



Depuis de nombreuses années, **EISMO** est connu et reconnu internationalement dans le domaine du sciage, tronçonnage, usinage et fraisage de barres et de profilés en ALU et en ACIER.

EISMO a su mettre en place un solide partenariat avec des fabricants de machines-outils européens, afin de concevoir et de fabriquer des machines selon son propre cahier des charges. Ainsi, nous sommes à même de proposer à nos clients des machines techniques de grande qualité en gardant des tarifs très compétitifs.

EISMO a récemment élargi ses savoir-faire avec une nouvelle compétence : l'aspiration pour machines industrielles afin d'avoir une solution dans tous les domaines (ALU, verre, sable,... mais aussi avec des solutions innovantes, comme la séparation des copeaux et des fluides sur les fraiseuses, tours ou centres d'usinage à CNC).

Aujourd'hui, nos produits sont présents dans de nombreux domaines de l'Industrie et de l'Artisanat français, tels que la menuiserie (fabricants de fenêtres, portails, vérandas, ...), la construction métallique, la construction navale et aéronautique, l'armement, la chaudronnerie, la maintenance, ...



SUR LE TERRAIN : une présence nationale

EISMO c'est 8 **technico-commerciaux exclusifs** et un réseau de techniciens répartis sur tout le territoire français. Notre force est d'être au plus proche de nos clients.

Quel que soit votre besoin pour vos travaux de sciage, d'usinage ou d'aspiration, nous sommes capables de vous apporter conseils, expertise, supports techniques et de vous proposer les machines les mieux adaptées.



SIEGE : une entreprise structurée

Nous disposons d'un important show-room avec diverses machines en démonstration permettant de réaliser tous types d'essais de coupe. Celui-ci vous est bien évidemment ouvert. Accolé, un atelier de maintenance de 2000 m² nous permet d'effectuer les réglages et réparations sur vos machines.

Nos équipes sédentaires assurent la rédaction des offres commerciales, le suivi et la gestion des commandes, l'expédition et la facturation dans les meilleurs délais.



STOCK : une réactivité accrue

Afin d'être le plus réactif possible face aux besoins de nos clients, nous disposons d'un **stock permanent de près de 300 machines**, ainsi que la plupart des pièces détachées et des consommables.



FORMATION : centre agréé



EISMO est centre de formation agréé par l'Etat, cela nous permet d'assurer des formations de qualité mais aussi de répondre aux dispositions légales obligatoires dans ce domaine. Nous sommes certifié QUALIOPI depuis le 18 décembre 2021.



GARANTIE : un service de professionnel

Nos équipes assurent les mises en route, mais aussi les maintenances et réparations tout au long du cycle de vie de vos machines, que ce soit dans ou hors périodes de garantie.

Chacun de nos techniciens ou ingénieurs a à coeur de vous offrir le meilleur service avec un maximum de réactivité car nous sommes conscients de l'importance que nos machines représentent dans votre activité !

Nous sommes capables d'étudier toutes lignes de sciage, perçage et taraudage avec magasins de chargement et déchargement automatisés

CONCEPTION SUR MESURE

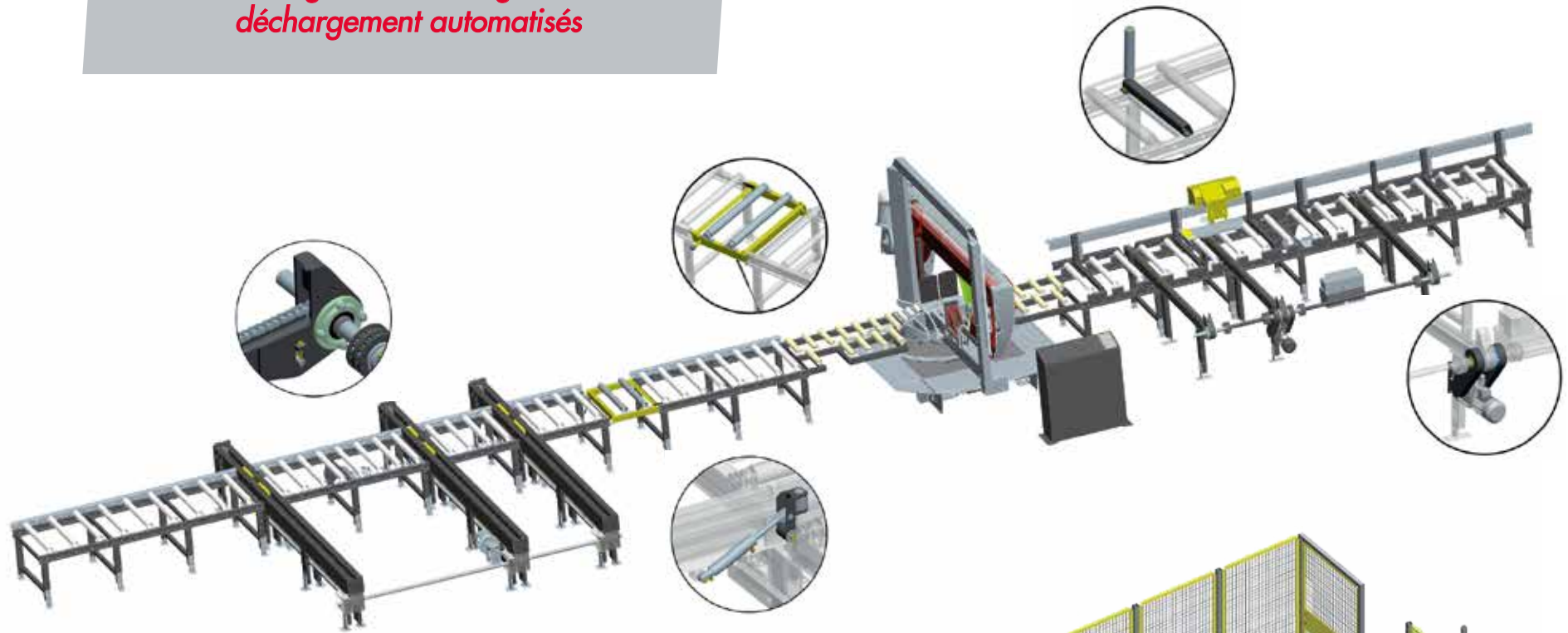

SÉCURITÉ - les enceintes grillagées

Un système de protection complet et modulable avec panneau fixe, poteau de fixation, porte de service complète, barrière immatérielle, ...

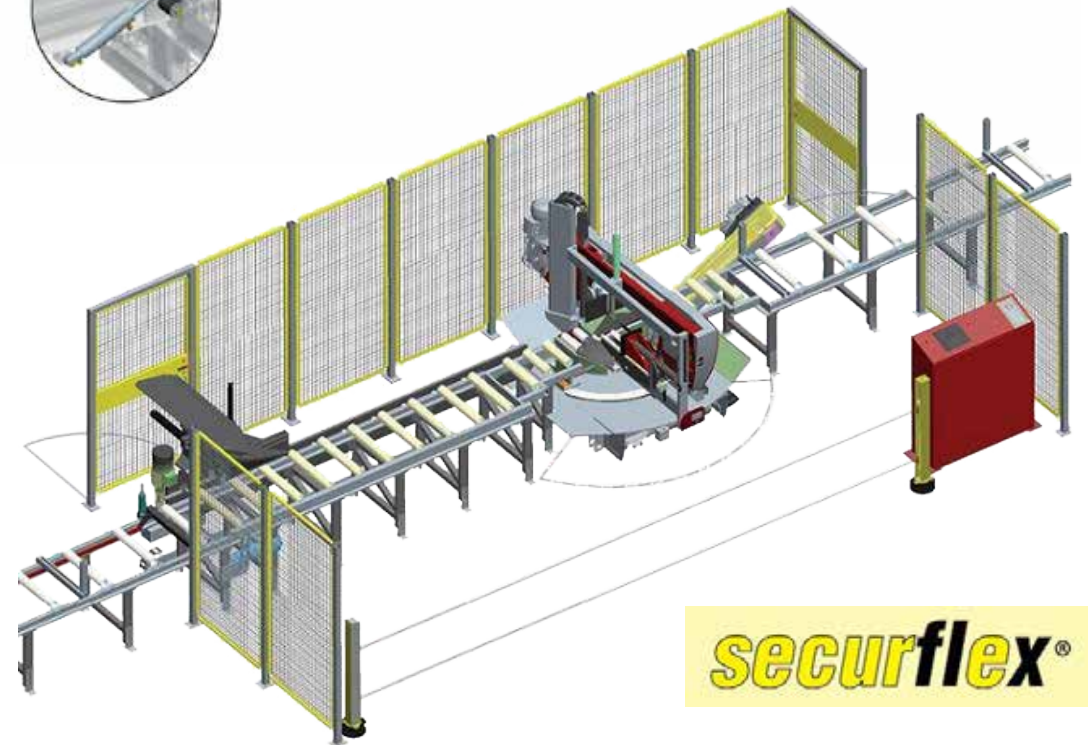

securflex®

AUTOMATIQUES

*Avance-barre de longueur 500 à 12000 mm
(selon modèle)*

ACIER

INDIVIDUAL 520.360 DGA



EXTEND 800.620 A

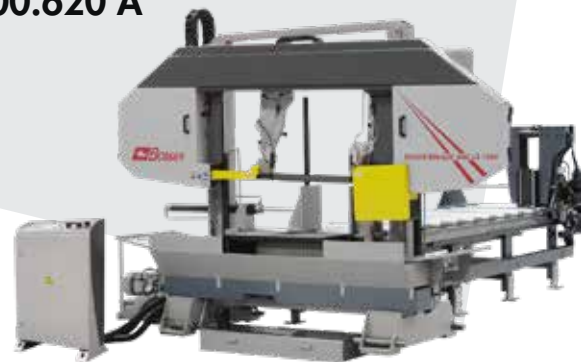

PROLINE 280 ANC



PROFICUT 275.230 GANC



SEMI-AUTOMATIQUES

WORKLINE 450 DGH



CLS 420
Spécial découpe
des impressions 3D



SCIAGE

Nos machines ont une capacité de coupe allant du Ø 5 mm au Ø 3300 mm avec des angles de coupe de - 30° à + 30° (selon modèle)

SEMI-AUTOMATIQUES



CONSTRUCTION 600 DGS

ERGONOMIC 320.258 DGH



MANUELLES



ERGONOMIC 340.278 DG



EASYCUT 275.230 DG



SINGLE 250 II



BSANDER 100.1220

BSANDER 150.200



BASIC 200

ORBITAL 250 NII
Intérieur et extérieur



MANUELLES



PULLDOWN 120
Avec ou sans bâti



BASICUT 275.230 DG

TRONÇONNAGE

SCIES À RUBAN

ERGONOMIC 290.258 DGA



SLE - Magasin de chargement



GSP - Tapis d'évacuation



PRODUCTION 280 ANC



TRONÇONNEUSES de PRODUCTION à fraise-scie

TAC 75
Précision & Cadence



AUTOMATIQUES



WS 370 ANC



MAGASIN DE CHARGEMENT



SLB 6000

SEMI-AUTOMATIQUES

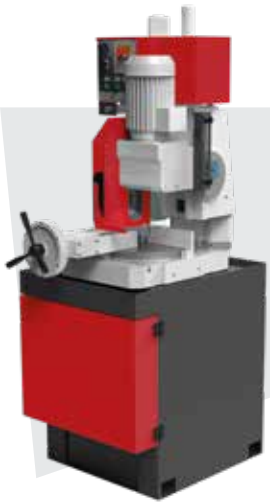

WS 315 SA



WS 370 SA

MANUELLES



WS 315 M



WS 370 M

CENTRE de DÉBIT et d'USINAGE



ALM 6510



CENTRE d'USINAGE à CN 5 AXES



P 527 PREMIUM +





P 107

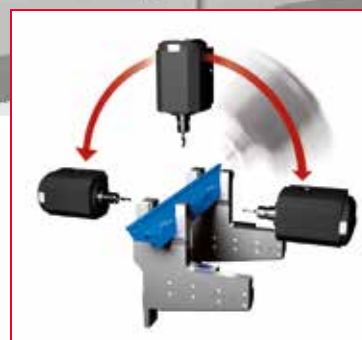

P 104 ESSENTIAL



P 104 PREMIUM



à déplacement **AUTOMATIQUE**

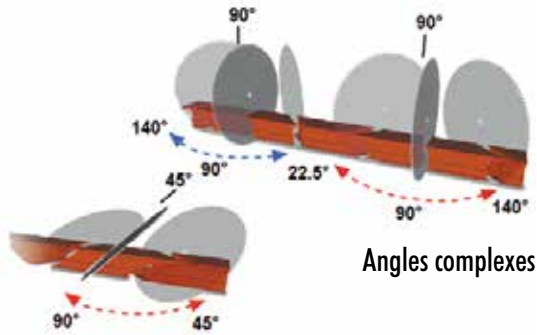

CDC 600
Pivotement et basculement motorisés



DC 550 SKH
Pivotement motorisé

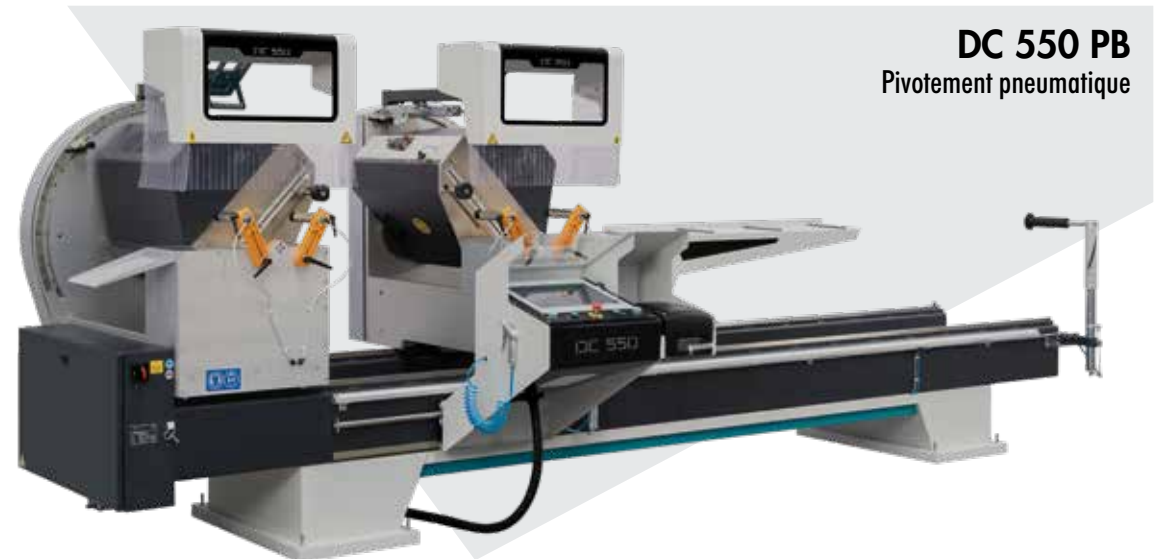
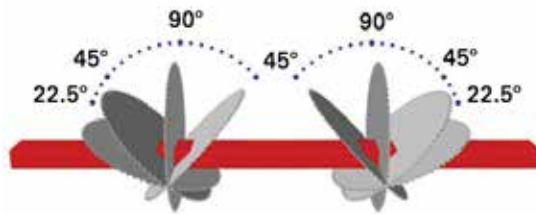
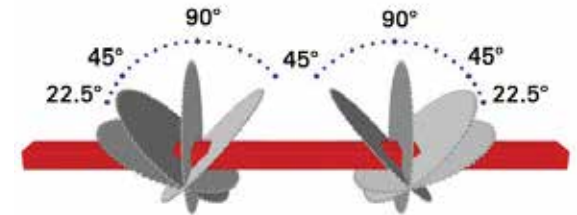

DC 550 PB
Pivotement pneumatique

à déplacement **AUTOMATIQUE**

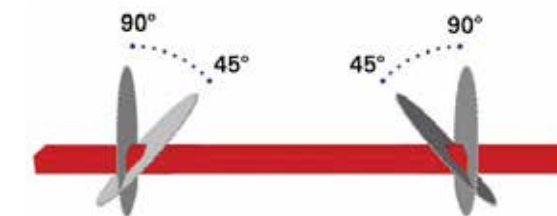

DC 421 PBS
Pivotement pneumatique

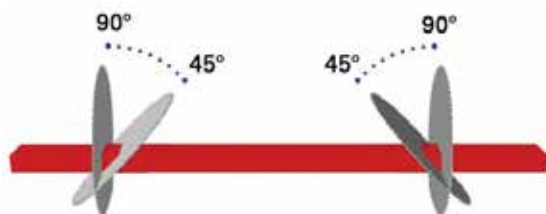

DC 421 PSD
Pivotement pneumatique



à déplacement **MANUEL**

KD 402 S
Orientation manuelle

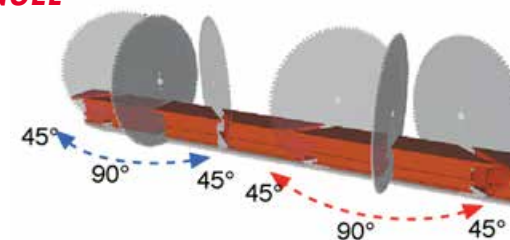

AUTOMATIQUES

Fraise-scie jusqu'à Ø 700 mm avec angles de coupe de - 10° à + 10° (selon modèle)



SK 500 D
Avec ou sans module de perçage

DÉLIGNAGE



RIF 35

SEMI-AUTOMATIQUES

ACK 700



SEMI-AUTOMATIQUES



ACK 420 S



TMA 60



MANUELLES



RYK 420 S



KD 400 PS

CENTRE de DÉBIT et d'USINAGE



PIM 6509

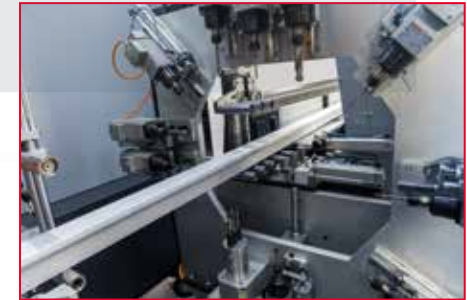

LIGNE de PRODUCTION de fenêtres PVC

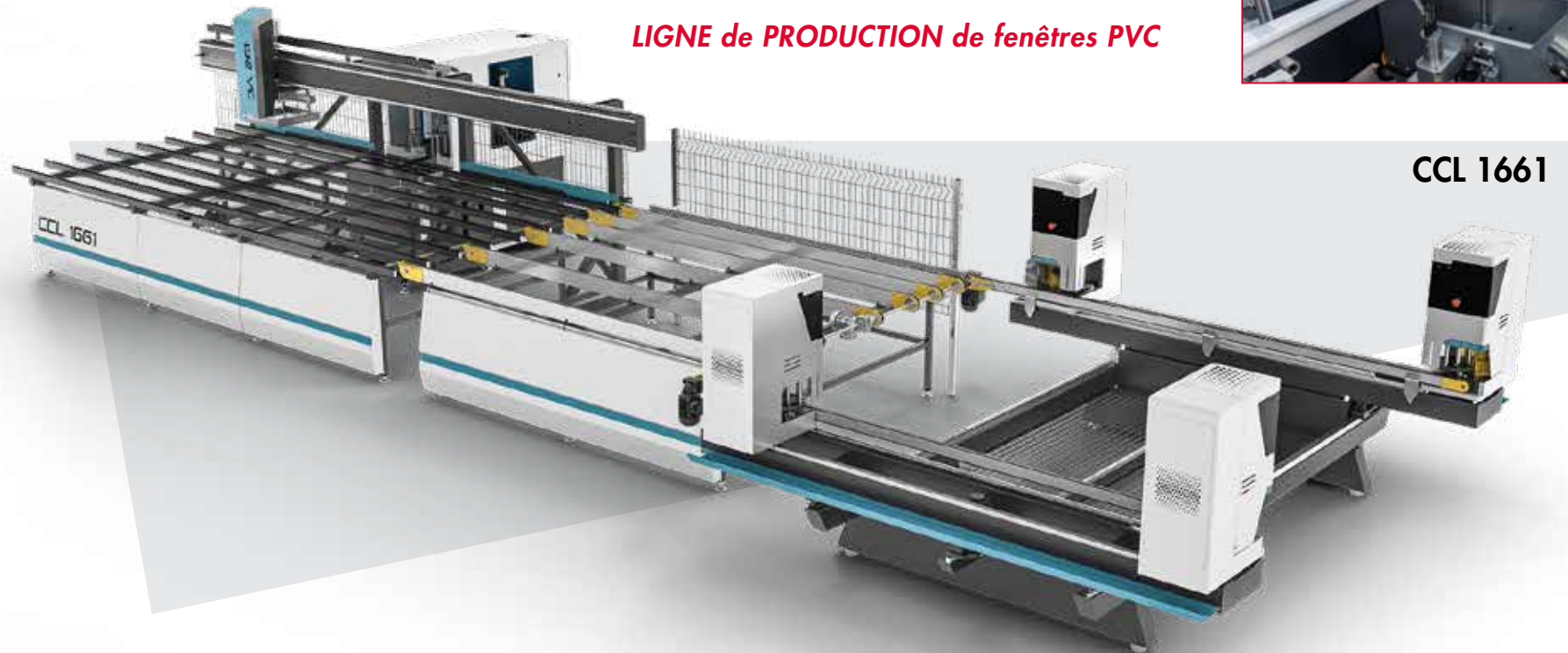

CCL 1661

SOUDEUSES

ÉBAVUREUSES

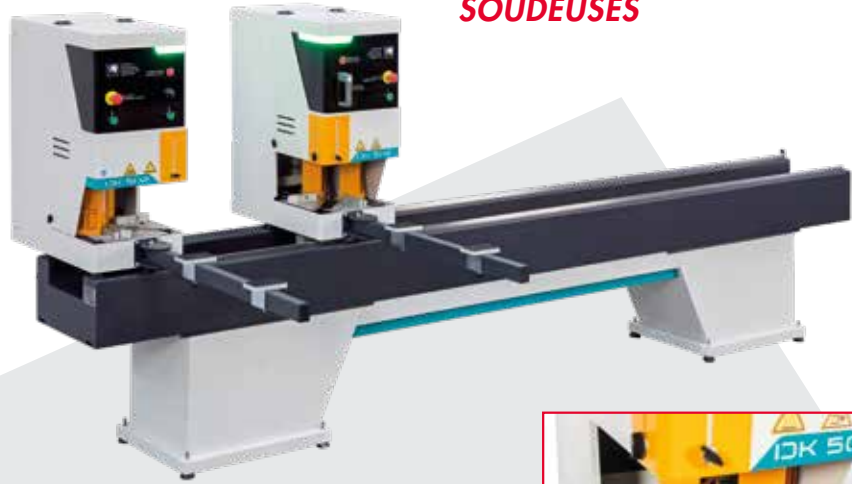

DK 502
Soudeuse d'angles 2 têtes



CA 603
Ebavureuse d'angles à 4 couteaux



CNC 610
Ebavureuse d'angles 4 axes

TRONÇONNEUSE



CK 412
Tronçonneuse à parcloses

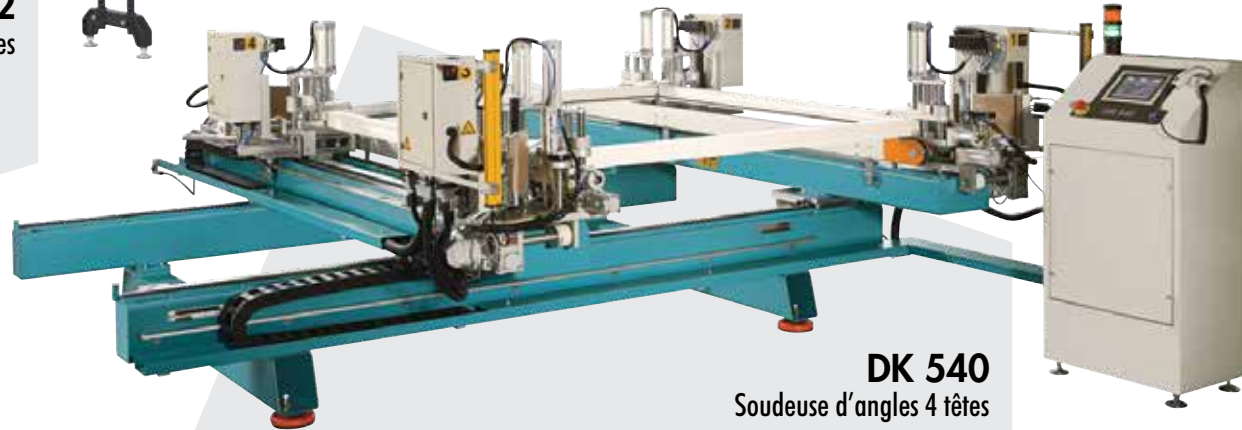

DK 540
Soudeuse d'angles 4 têtes

EXTRUSION Line
Aspirateurs industriels
pour copeaux d'aluminium et de PVC



EXTRUSION 160



EXTRUSION 100



CLEAN 38



CLEAN Line
Aspirateurs industriels pour tous les nettoyages



SAND Line
Aspirateurs industriels
pour sable et verre



EMULSIO Line
Aspirateurs industriels
pour la collecte et la séparation
de copeaux et d'huile

WOOD Line
Aspirateurs industriels
pour copeaux bois et poussières



Fraiseuses à COPIER



FC 380 SLI
Fraisage sur 3 faces

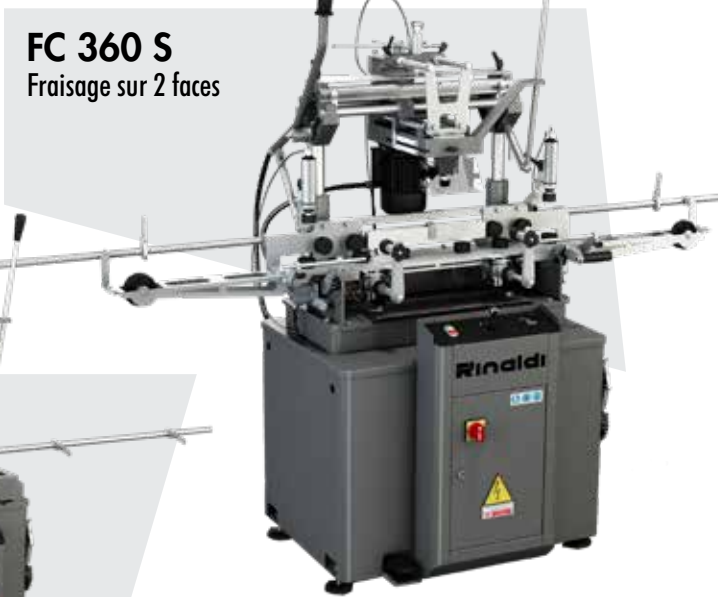

FC 360 S
Fraisage sur 2 faces



FCSR
Fraisage sur 2 faces



FR 222
Fraiseuse de chantier

Fraiseuses en BOUT



AKF 160 R
Manuelle ou semi-automatique



FC 22
Fraiseuse de chantier



KM 212
Fraiseuse en bout de chantier

Fraiseuses à 2 LAMES

Fraiseuses en BOUT



SNM 560 SRV



VK 420

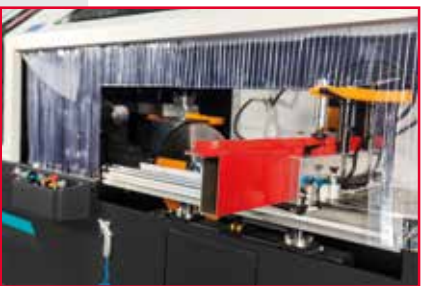

PRIMUS 300



Fraiseuses PVC

ST 264
Pour canaux d'évacuation



RPS
Tronçonneuse pour
profilés de volets roulants



AT 3000
Table de préparation
des tabliers de lames de volets



ACK 420 ACIER
Spécial axes de volets roulants

RKS
Tronçonneuse pour
caissons de volets roulants



Charge admissible : 150 kg/m



ROLBO
motorisée

Charge admissible : 1500 kg/m



XNCA
motorisée

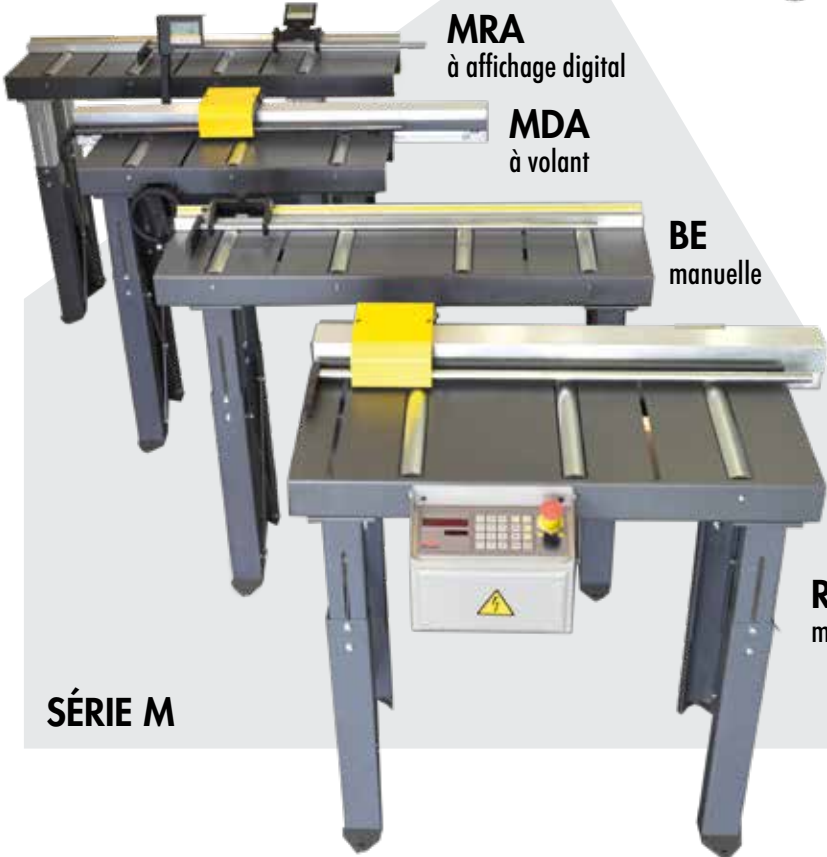

MRA
à affichage digital

MDA
à volant

BE
manuelle

ROLBO
motorisée

SÉRIE M

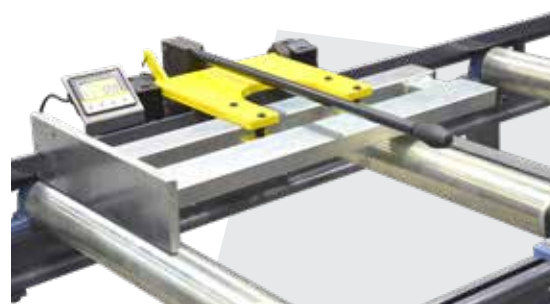

XRA
à affichage digital



XDA
à volant

GRIGNOTAGE

ROTOLIMA
Pour parcloses



SERTISSAGE



ITACA
Pneumatique



PERÇAGE multi-broche



FULL 22 P



KP 120
Hydraulique



ECO
Pneumatique

PERÇAGE

P 23 T
Perceuse taraudeuse



P 23 VDA
Perceuse automatique



COMPRESSEURS insonorisés

SILENT K30



P 23 S
Perceuse
en version à colonne

AIR SIL2 NB7



AUTRES savoir-faire

WB 4000
Table de montage universelle extensible



HP 1000
Chariot de manutention à stockage horizontal



GT 1000
Dévidoir à joint pour 4 bobines

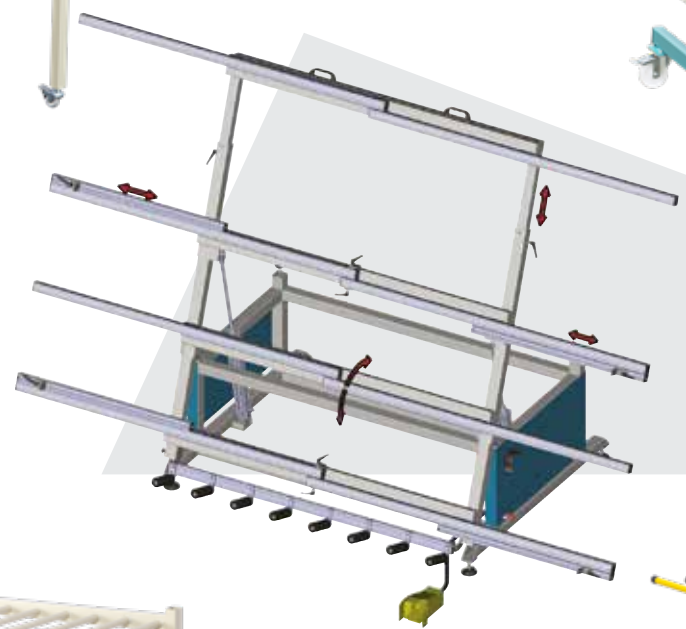
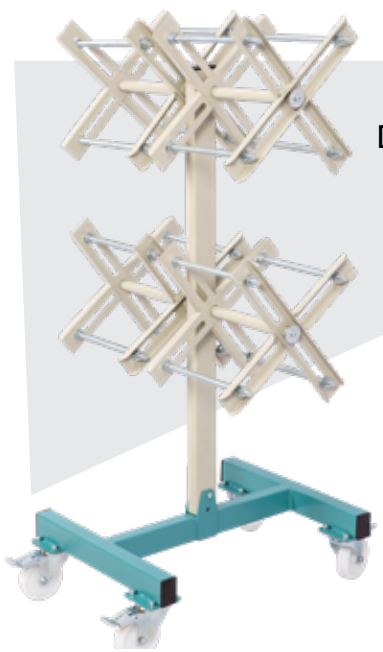

PWB 4100
Table de montage à basculement pneumatique

VP 1000 **VP 2000**
Chariot de manutention à stockage vertical



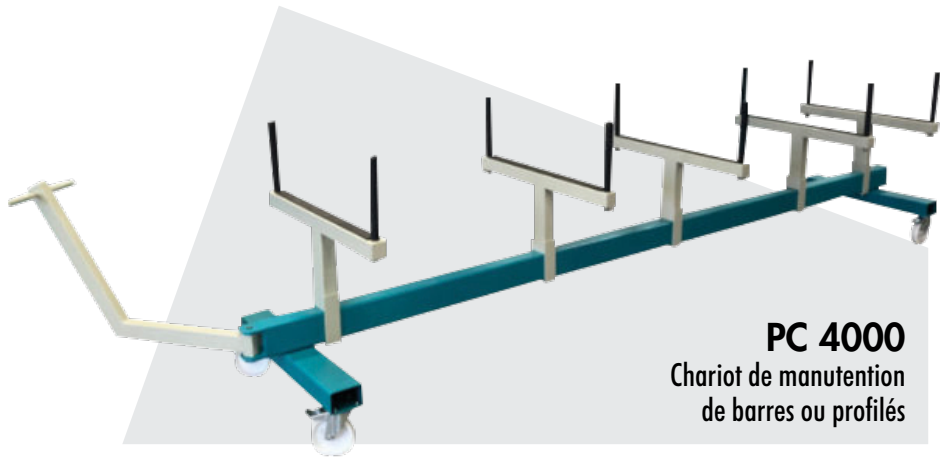

PC 4000
Chariot de manutention
de barres ou profilés

GPT 1000
Chariot
porte-châssis



RT 1000
Table de montage
rotative en croix



PT 1000
Chariot
porte-châssis

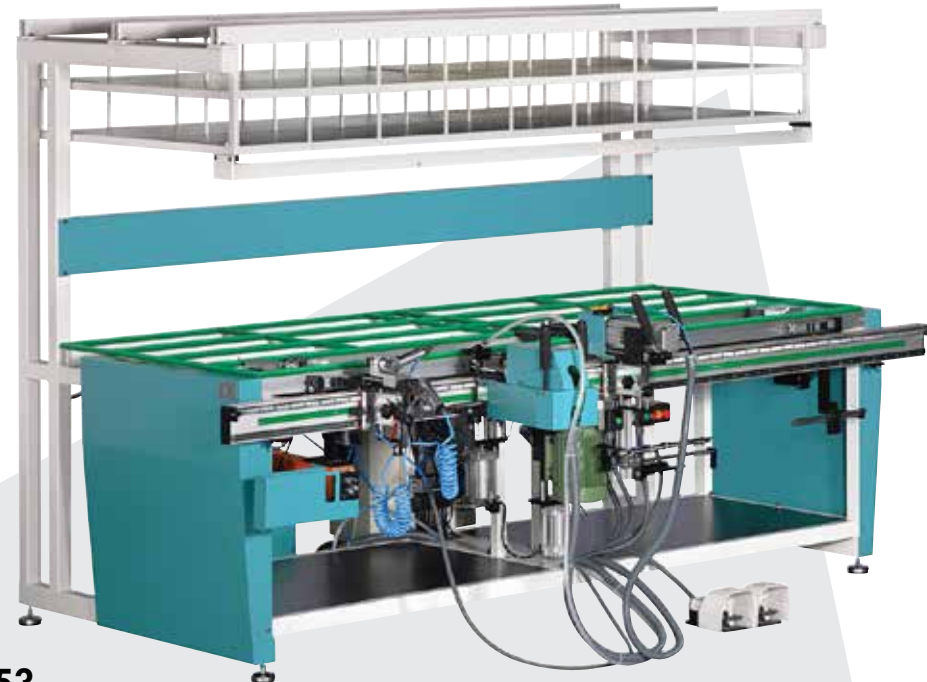

NSM 353
Table de ferrage

MACHINES POUR LA COUPE DES METAUX **EISMO**
MACHINES POUR L'USINAGE ALU **EISMO**



Une large gamme de consommables

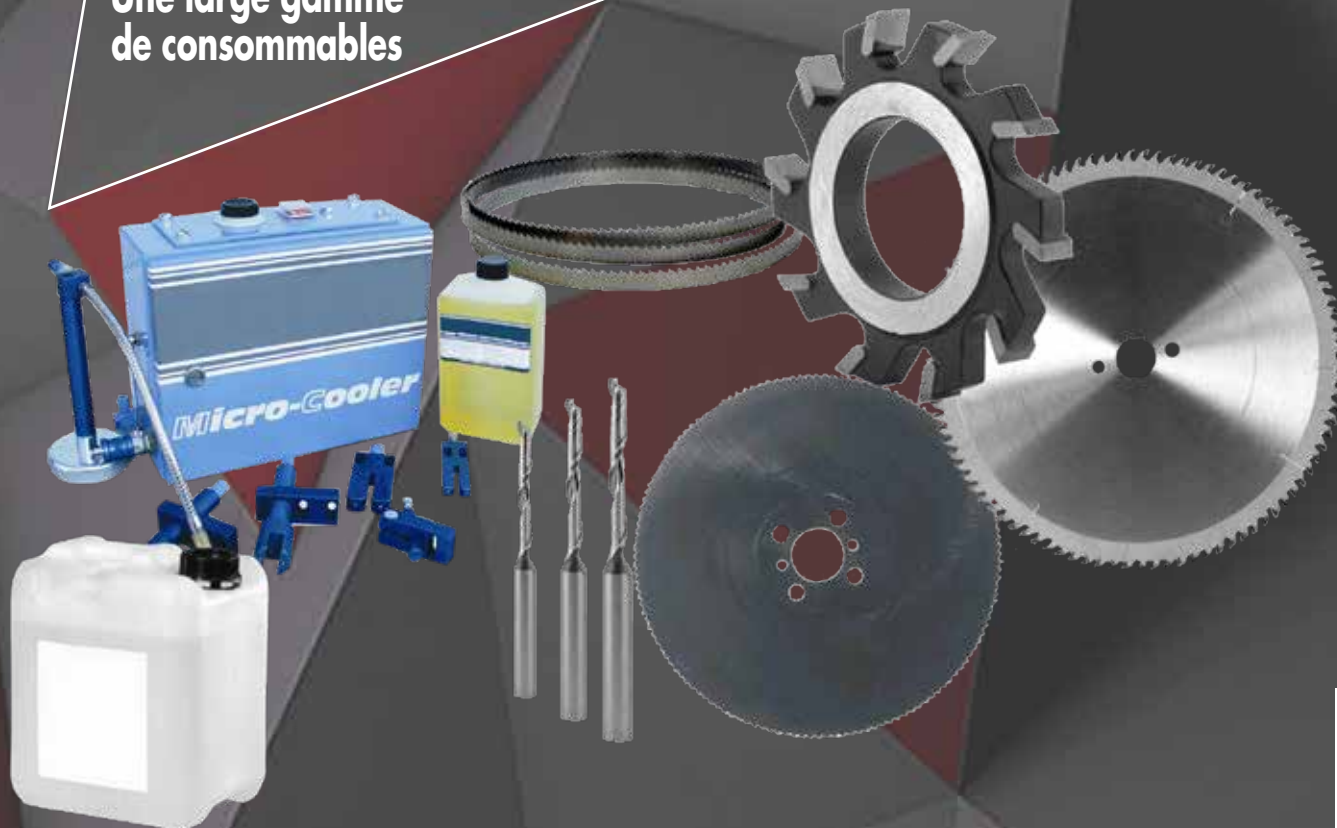

L'exigence EISMO :
C'est aussi la garantie de
consommables originaux
pour vos machines !

EISMO

Anciennement EISELE DIFFUSION
10, rue de l'Artisanat - CS 70015
F - 68730 BLOTZHEIM

Tel. 03 89 68 45 66

Internet : www.eismo.fr
E-mail : eismo@eismo.fr

